

Slot diffusers for installation in walls Type VSD50-1-LT



For the space saving installation into lightweight partition walls with Metal support structure

Slot diffusers with 50 mm diffuser face (nominal width) and adjustable air control elements

- Nominal length: 550, 1175 mm, 1 slot
- Volume flow rate range 10 – 70 l/s or 36 – 252 m³/h
- Diffuser face made of extruded aluminium sections
- For variable and constant volume flows
- Installation into lightweight partition walls with a 50 mm wide metal support structure and a wall thickness of 100 mm
- High induction results in a rapid reduction of the temperature difference and airflow velocity
- Individually adjustable air control elements to meet individual local requirements

Optional equipment and accessories

- Exposed diffuser face available in RAL CLASSIC colours
- Damper blade for volume flow rate balancing, can be adjusted through the diffuser face



Angled one-way air discharge

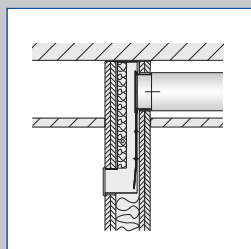

Installation in lightweight partition walls with metal support structure

Type		Page
VSD50-1-LT	General information	VSDLT – 2
	Function	VSDLT – 4
	Technical data	VSDLT – 6
	Quick sizing	VSDLT – 7
	Specification text	VSDLT – 9
	Order code	VSDLT – 10
	Variants	VSDLT – 11
	Dimensions and weight	VSDLT – 12
	Product details	VSDLT – 13
	Installation details	VSDLT – 14
	Commissioning	VSDLT – 15
	Basic information and nomenclature	VSDLT – 16

Application

Application

- Type VSD50-1-LT slot diffusers are used as supply air or extract air devices or as supply and extract air combinations in comfort zones
- Angled one-way air discharge for turbulent flow (mixed flow ventilation)
- High induction causes rapid reduction of temperature difference and airflow velocity (with supply air)
- For constant and variable volume flow rates
- For supply air to room air temperature differences of –10 to +10 K
- For rooms up to approx. 4 m in height (bottom edge of finished ceiling)
- For the space saving installation into light-weight partition walls with a 50 mm wide metal support structure and a wall thickness of 100 mm

Special characteristics

- Individually adjustable air control elements to meet individual local requirements
- High induction results in a rapid reduction of the temperature difference and airflow velocity
- Face plate optimised for maximum volume flow at low sound power levels
- Internal acoustic lining that reduces room-to-room cross talk through the ductwork
- For easy and safe installation of the diffuser face after drywalling is complete

Nominal sizes

- L_N: 550, 1175 mm

Description

Variants

- VSD50 -1-LT: Slot diffuser for supply air or extract air
- VSD50 -1-LT-AZ: Slot diffuser as a supply and extract air combination (only L_N 1175 mm)
- VSD50 -1-LT-.../WW: White air control elements

Parts and characteristics

- Diffuser face with individually adjustable air control elements
- Plenum box for horizontal duct connection
- Internal acoustic lining to increase transmission loss
- Spring clip fixing

Attachments

- Damper blade for volume flow rate balancing

Accessories

- Lip seal

Construction features

- Spigot matching round ducting according to EN 1506 or EN 13180
- Spigot with groove for lip seal (if accessory lip seal has been ordered)

Materials and surfaces

- Face plate made of extruded aluminium section
- Air control elements made of plastic, UL 94, V-0, flame retardant
- Plenum box made of galvanised sheet steel
- End angle made of aluminium
- Lip seal made of rubber
- Acoustic lining of the cross-talk attenuator is mineral wool
- Face plate with anodised finish, E6-C-0, natural colour
- P1: Powder-coated, RAL CLASSIC colour
- Air control blades similar to RAL 9005, black
- WW: Air control elements similar to RAL 9010, white

Mineral wool

- According to EN 13501, material classification A1, non-flammable
- RAL quality mark RAL-GZ 388
- Hygienically safe due to high biosolubility, according to TRGS 905 and EU Directive 97/69/EC
- Faced with glass fibre fabric as a protection against abrasion through airflow velocities of up to 20 m/s
- Inert to the growth of fungus and bacteria

Standards and guidelines

- Sound power level of the air-regenerated noise measured according to EN ISO 5135

Maintenance

- Maintenance-free as construction and materials are not subject to wear
- Inspection and cleaning according to VDI 6022

Functional description

Slot diffusers direct the air from air conditioning systems into the room, either horizontally or at an angle. The flow takes place with high induction of indoor air and consequently with a rapid reduction of airflow velocity and temperature difference between supply air and indoor air. The result is a mixed flow ventilation in comfort zones, with good overall room ventilation, creating only very little turbulence in the occupied zone.

Type VSD50-1-LT slot diffusers have adjustable air control elements. The air pattern can be adjusted to meet various local requirements. The supply air to room air temperature difference can be -10 to +10 K.

A damper blade (optional) simplifies volume flow rate balancing for commissioning.

To give rooms an aesthetic, uniform look, Type VSD50-1-LT diffusers may also be used for extract air or as a supply and extract air combination.

Schematic illustration of VSD50-1-LT as supply and extract air combination



Angled one-way air discharge



Nominal length	550, 1175 mm
Number of slots	1
Minimum volume flow rate	10, 25 l/s or 36, 90 m ³ /h
Maximum volume flow rate, at $L_{WA} \cong 50$ dB(A)	35, 70 l/s or 126, 252 m ³ /h
Supply air to room air temperature difference	-10 to +10 K

Transmission loss

Variant	Centre frequency f_m [Hz]				
	125	250	500	1000	2000
	D_t				
	dB				
VSD50-1-LT/550	16	14	15	18	22
VSD50-1-LT/1175	13	12	11	17	20
VSD50-1-LT-AZ/1175	15	13	13	17	20

The quick sizing table gives a good overview of the possible volume flow rates and the corresponding sound power levels and differential pressures.

The maximum volume flow rates apply to a sound power level of approx. 50 dB (A) with damper blade position 0°.

VSD50-1-LT, supply air, sound power level and total differential pressure

Nominal length	\dot{V}	\dot{V}	Damper blade position					
			0°		45°		90°	
	l/s	m ³ /h	Δp_t Pa	L_{WA} dB(A)	Δp_t Pa	L_{WA} dB(A)	Δp_t Pa	L_{WA} dB(A)
550	10	36	7	<15	11	<15	29	<15
	15	54	17	18	24	23	64	22
	25	90	46	34	66	38	179	40
	35	126	90	45	130	47	350	51
1175	25	90	18	19	26	24	63	26
	45	162	60	36	86	40	204	42
	55	198	89	43	128	45	305	47
	70	252	145	50	207	52	494	54

VSD50-1-LT, extract air, sound power level and total differential pressure

Nominal length	\dot{V}	\dot{V}	Damper blade position					
			0°		45°		90°	
	l/s	m ³ /h	Δp_t Pa	L_{WA} dB(A)	Δp_t Pa	L_{WA} dB(A)	Δp_t Pa	L_{WA} dB(A)
550	10	36	7	<15	9	<15	33	18
	15	54	16	15	21	18	74	31
	25	90	43	37	59	39	205	47
	35	126	85	51	116	53	401	58
1175	25	90	18	17	26	20	62	26
	45	162	59	34	85	38	199	42
	55	198	89	40	126	44	298	48
	70	252	144	47	204	51	483	54

VSD50-1-LT-AZ, supply and extract air combination, sound power level and total differential pressure

Nominal length	\dot{V}	\dot{V}	Damper blade position								
			0°			45°			90°		
			Δp_t Sup- ply air	Δp_t Extract air	L_{WA}	Δp_t Sup- ply air	Δp_t Extract air	L_{WA}	Δp_t Sup- ply air	Δp_t Extract air	L_{WA}
			Pa		dB(A)	Pa		dB(A)	Pa		dB(A)
1175	10	36	7	6	<15	12	10	15	30	33	17
1175	15	54	15	13	20	26	23	26	68	75	29
1175	25	90	43	35	36	72	64	40	188	208	45
1175	40	144	110	90	50	186	163	53	482	532	61

This specification text describes the general properties of the product. Texts for variants can be generated with our Easy Product Finder design programme.

Slot diffusers with individually manually adjustable air control elements and an aesthetically shaped face section with one wide slot, for angled air discharge. For supply air, extract air or as a supply and extract air combination. For installation in lightweight partition walls with metal support structure.

Ready-to-install component which consists of the diffuser face with individually adjustable black or white air control elements, and of a plenum box with side entry spigot and acoustic lining to reduce room-to-room cross talk.

Diffuser face with screw fixing to the plenum box. Spigot suitable for circular ducts to EN 1506 or EN 13180.

Sound power level of the air-regenerated noise measured according to EN ISO 5135.

Special characteristics

- Individually adjustable air control elements to meet individual local requirements
- High induction results in a rapid reduction of the temperature difference and airflow velocity
- Face plate optimised for maximum volume flow at low sound power levels
- Internal acoustic lining that reduces room-to-room cross talk through the ductwork
- For easy and safe installation of the diffuser face after drywalling is complete

Materials and surfaces

- Face plate made of extruded aluminium section
- Air control elements made of plastic, UL 94, V-0, flame retardant
- Plenum box made of galvanised sheet steel
- End angle made of aluminium
- Lip seal made of rubber
- Acoustic lining of the cross-talk attenuator is mineral wool
- Face plate with anodised finish, E6-C-0, natural colour
- P1: Powder-coated, RAL CLASSIC colour
- Air control blades similar to RAL 9005, black
- WW: Air control elements similar to RAL 9010, white

Mineral wool

- According to EN 13501, material classification A1, non-flammable
- RAL quality mark RAL-GZ 388
- Hygienically safe due to high biosolubility, according to TRGS 905 and EU Directive 97/69/EC
- Faced with glass fibre fabric as a protection against abrasion through airflow velocities of up to 20 m/s
- Inert to the growth of fungus and bacteria

Technical data

- Nominal lengths: 550, 1175 mm
- Number of slots: 1
- Minimum volume flow rate: 10, 25 l/s or 36, 90 m³/h
- Maximum volume flow rate, at $L_{WA} \cong 50$ dB(A): 35, 70 l/s or 126, 252 m³/h
- Supply air to room air temperature difference: -10 to +10 K

Sizing data

- \dot{V} _____
[m³/h]
- Δp_t _____
[Pa]
- Air-regenerated noise
- L_{WA} _____
[dB(A)]

VSD50-1-LT

VSD50 – 1 – LT – AZ – M – L / 1175 / P1 – RAL ... / WW						
1	2	3	4	5	6	7

1 Type

VSD50-1-LT Slot diffuser for lightweight partition walls

2 Construction

No entry: supply or extract air

AZ Supply and extract air combination (only nominal size 1175 mm)

3 Damper blade for volume flow rate balancing

No entry: none

M With

4 Accessories

No entry: none

L With lip seal

5 Nominal size [mm]

Nominal length L_N

550

1175

6 Exposed surface

No entry: anodised, E6-C-0, natural colour

P1 Powder-coated, specify RAL Classic colour

Gloss level

RAL 9010 50 %

RAL 9006 30 %

All other RAL colours 70 %

7 Colour of air control elements

No entry: Similar to RAL 9005, black

WW Similar to RAL 9010, white

Order example: VSD50-1-LT-AZ-M-L/1175/P1-RAL 9010/WW

Construction	Supply and extract air combination
Damper unit for volume flow rate balancing	With
Accessories	Lip seal
Nominal size	1175 mm
Exposed surface	RAL 9010, pure white, gloss level 50 %
Colour of air control elements	White

VSD50-1-LT/550



Black air control elements

VSD50-1-LT/550/.../WW



White air control elements

VSD50-1-LT-AZ/1175



Black air control elements

VSD50-1-LT

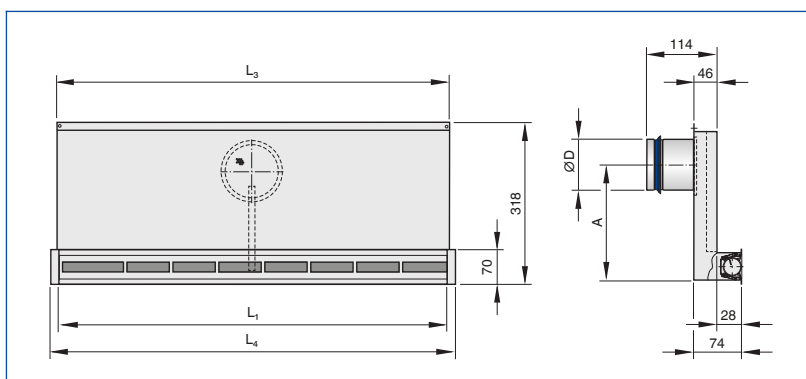

VSD50-1-LT

Nominal length	L ₁ mm	L ₃ mm	L ₄ mm	ØD mm	A mm	m kg
550	530	550	586	78	227	6.1
1175	1155	1175	1211	98	227	12.3

VSD50-1-LT-AZ

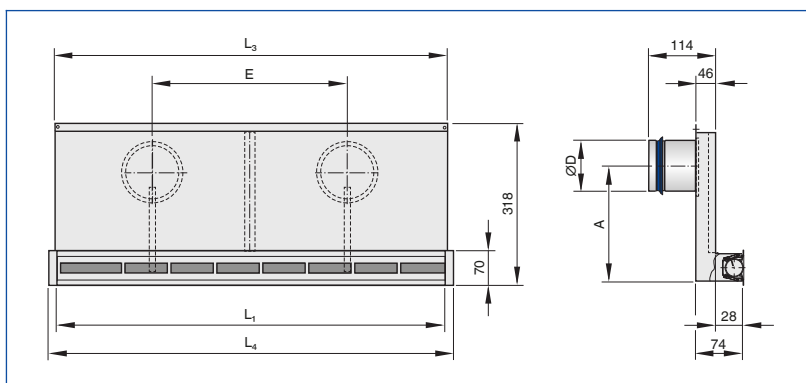

VSD50-1-LT-AZ

Nominal length	L ₁ mm	L ₃ mm	L ₄ mm	ØD mm	A mm	E mm	m kg
1175	1155	1175	1211	78	227	620	13.6

Profiles

VSD50-1-LT

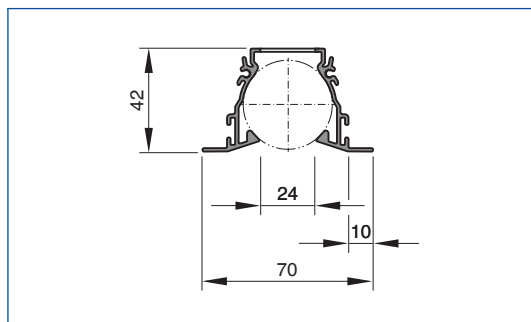

VSD50-1-LT

Nominal length	A_{eff}	
	m ²	
550		0.0055
1175		0.0118

A_{eff} : One-way angled air discharge (supply air)

Installation and commissioning

- Preferably for clear room heights up to 4.0 m
- Wall installation below the ceiling
- Installation together with drywalling
- Installation lengths correspond to the usual distances between the metal studs of stud walls
- Horizontal duct connection
- If necessary, carry out volume flow rate balancing on the damper unit

The illustrations are schematic and serve to better understand the installation details

Installation in lightweight partition walls with metal support structure

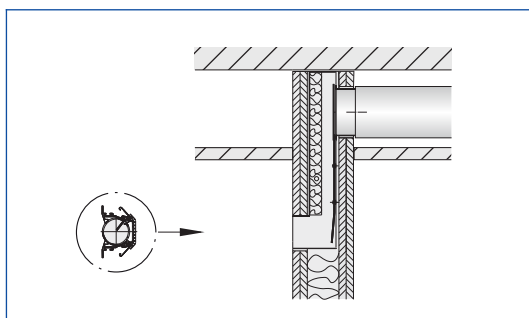

Installation opening in a lightweight partition wall

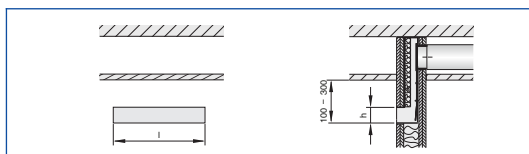

Installation opening

Nominal length	l	h
	mm	mm
550	560	58
1175	1185	58

Diffuser face fixing

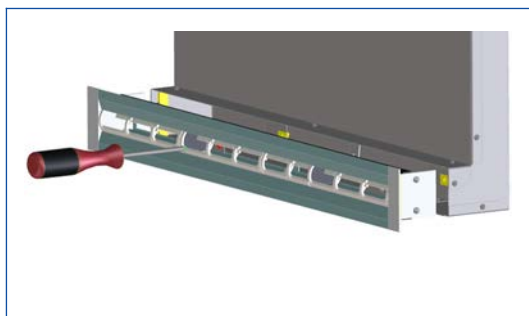

Volume flow rate balancing

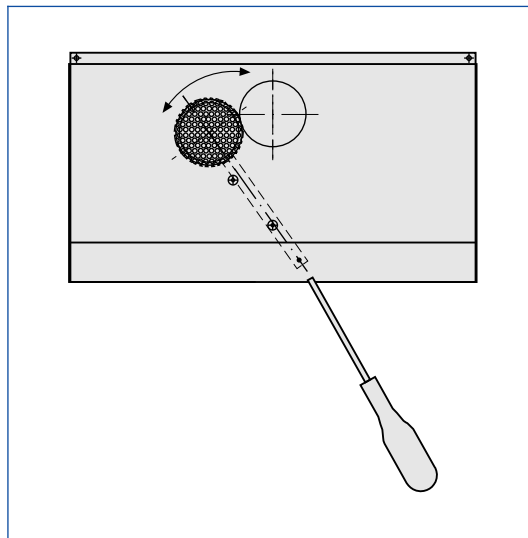

Open

Volume flow rate balancing

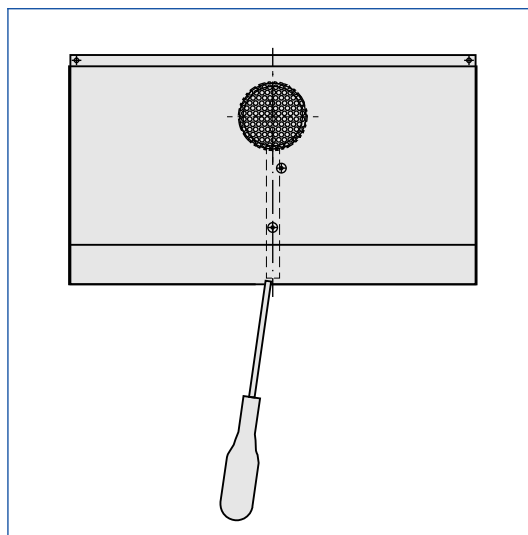

Closed (maximum restriction)

Principal dimensions

$\varnothing D$ [mm]

Outer diameter of the spigot

$\varnothing D_1$ [mm]

Outer diameter of a circular diffuser face

$\varnothing D_2$ [mm]

Diameter of a circular diffuser face style

$\varnothing D_3$ [mm]

Diameter of a circular plenum box

$\square Q_1$ [mm]

Outer diameter of a square diffuser face

$\square Q_2$ [mm]

Dimensions of a square diffuser face style

$\square Q_3$ [mm]

Dimensions of a square plenum box

H_1 [mm]

Distance (height) from the lower edge of the suspended ceiling to the lower edge of the diffuser face

H_2 [mm]

Height of a ceiling diffuser, from the lower edge of the suspended ceiling to the upper edge of the spigot

H_3 [mm]

Height of a ceiling diffuser with plenum box, from the lower edge of the suspended ceiling to the upper edge of the plenum box or of the spigot

A [mm]

Position of the spigot, defined by the distance of the spigot centre line to the lower edge of the suspended ceiling

C [mm]

Length of the spigot

m [kg]

Weight

Nomenclature

L_{WA} [dB(A)]

Sound power level of the air-regenerated noise, A-rated

\dot{V} [m^3/h] and [l/s]

Volume flow rate

Δt_z [K]

Supply air to room air temperature difference, supply air temperature minus room temperature

Δp_t [Pa]

Total differential pressure

A_{eff} [m^2]

Effective air discharge area

All sound power levels are based on 1 pW.